



Tube Firing Burners

Model TFB030

Version 2

| PARAMETER | | BURNER INPUT (1000's BTU/HR) | | |
|--|--|------------------------------|------------|------------|
| | | 100 | 200 | 300 |
| Low firing rate (1000's Btu/hr) At 100% excess air | Without Flame Safety | 5 | 5 | 5 |
| | With Flame Safety | 10 | 10 | 10 |
| Differential air pressure ("w.c.) between tap A and B (See Pages 3 & 4) | | 8.2 | 8.5 | 8.1 |
| Recommended air orifice diameter mm (in) | | 18 (0.70) | 24 (0.95) | 29 (1.13) |
| Air flow (SCFH) At 15% excess air | | 1150 | 2300 | 3450 |
| Differential gas pressure ("w.c.) between tap C and D (See Pages 3 & 4) | nat. gas | 4.3 | 4.0 | 4.4 |
| | propane | 1.7 | 3.8 | 4.0 |
| | butane | 6.0 | 5.5 | 6.8 |
| Recommended gas orifice plate mm (in) | nat. gas | 5.2 (0.20) | 7.6 (0.30) | 9.1 (0.36) |
| | propane | 5.2 (0.20) | 6.4 (0.25) | 7.6 (0.30) |
| | butane | 3.8 (0.15) | 5.2 (0.20) | 6.4 (0.25) |
| Piping | N.P.T. or B.S.P. burner piping is available. | | | |
| Flame detection | U.V. Scanner*, Flame Rod | | | |
| Ignition | direct spark ignition (6 kVAC) | | | |
| Fuels | Natural gas, propane, butane <i>For any other mixed gas, contact Eclipse Combustion</i> | | | |

* When using the U.V. scanner, mounting adapter part number 10033 will prevent the U.V. scanner from detecting the ignition spark.

Note: Pressures shown are for system sizing only. The supply pressure at the burner inlets must be at least 3" w.c. higher than the differential pressure shown in the tables.

- The low firing rate represents the capability of the burner. Achievement of this rate will be affected by the control method and ratio-regulator used in the system design.
- All inputs based on gross caloric values.
- Eclipse reserves the right to change the construction and/or configuration of our products at any time without being obliged to adjust earlier supplies accordingly.
- Plumbing of air and gas will affect accuracy of orifice readings. All information is based on generally acceptable air and gas piping practices.

Performance Graphs

Ignition and Operation Zone

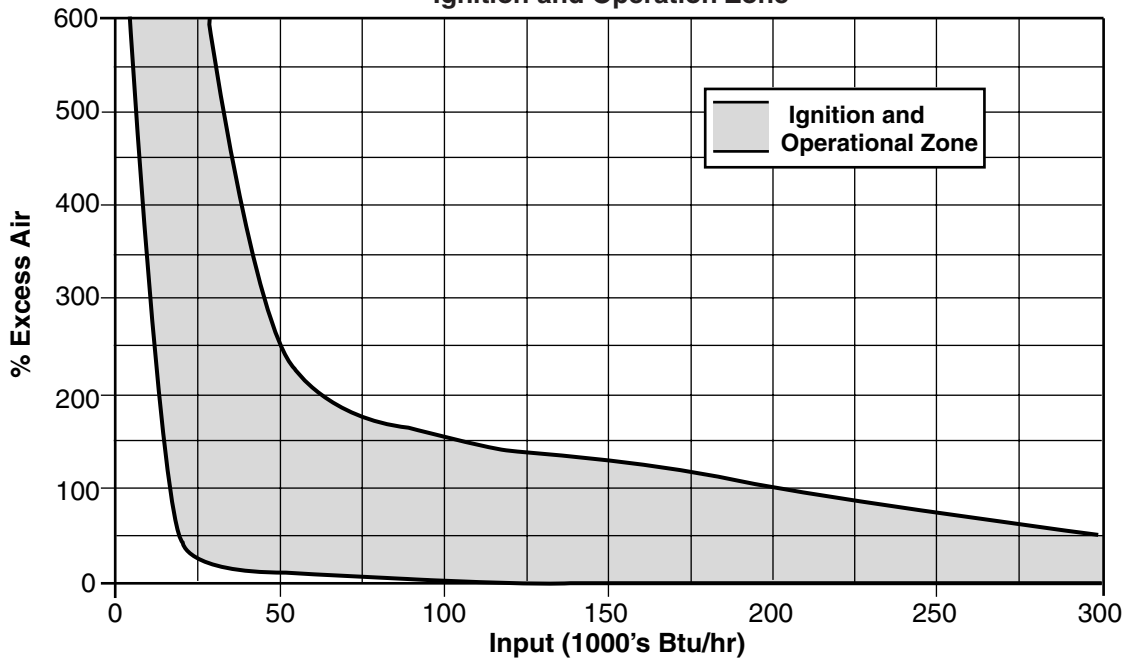

NO_x and CO Emissions (ambient air burner)

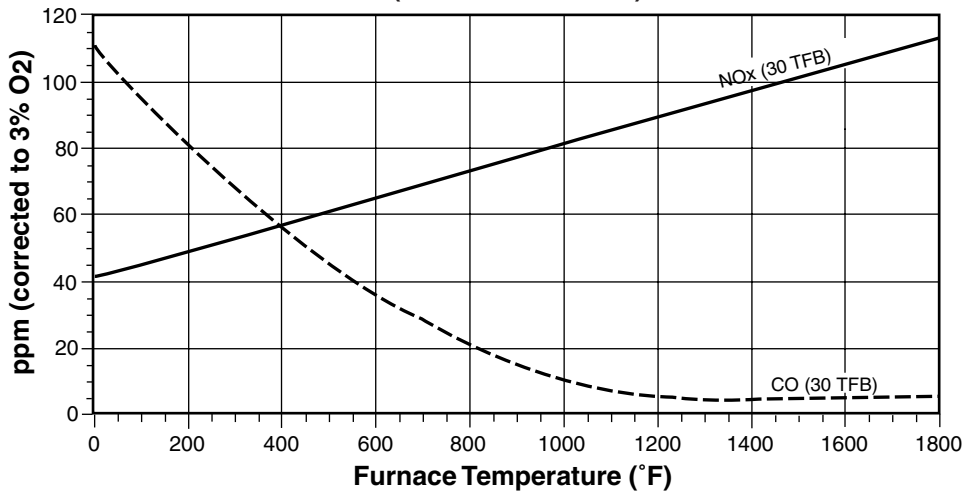

Emissions from the burner are influenced by:

- fuel type
- combustion air temperature
- chamber conditions
- percent of excess air

For estimates of other emissions, contact Eclipse Combustion.

NO_x and CO Emissions (pre-heated air burner)

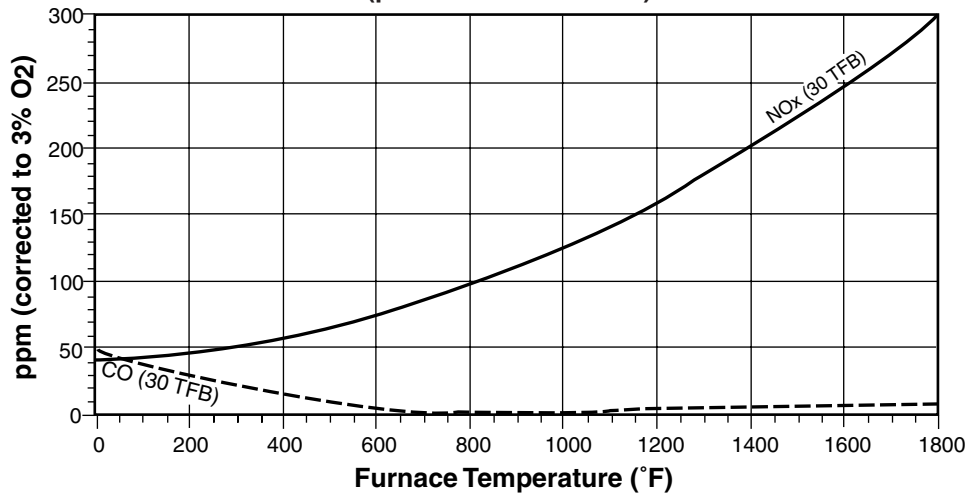

Performance Graphs (Cont.)

Air Orifice ΔP vs Input @ 3% O₂
(Measured from Tap A to Tap B)

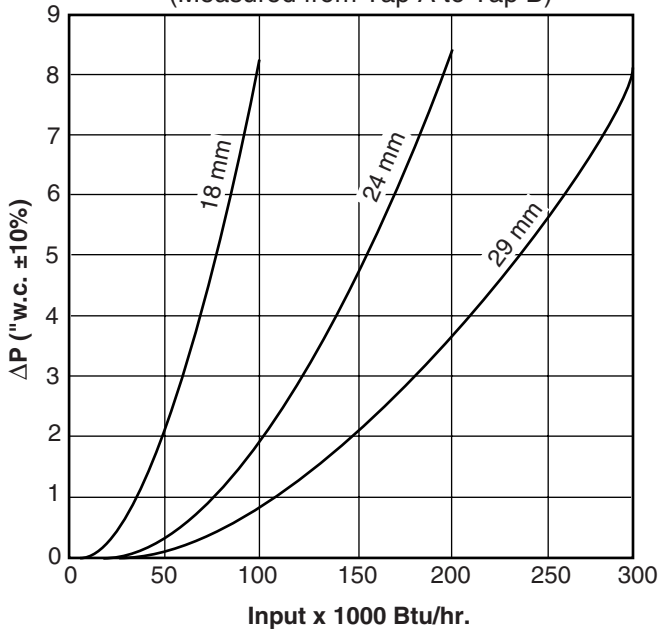

Natural Gas Orifice ΔP vs Input
(Measured from Tap C to Tap D)

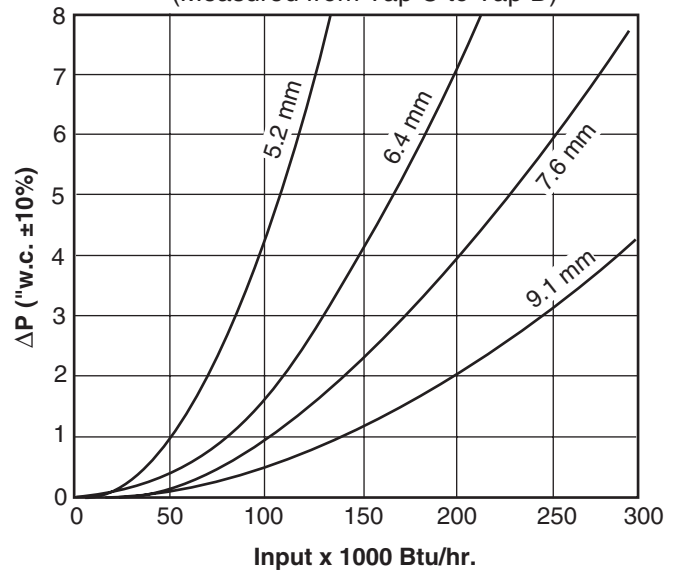

Propane Orifice ΔP vs Input
(Measured from Tap C to Tap D)

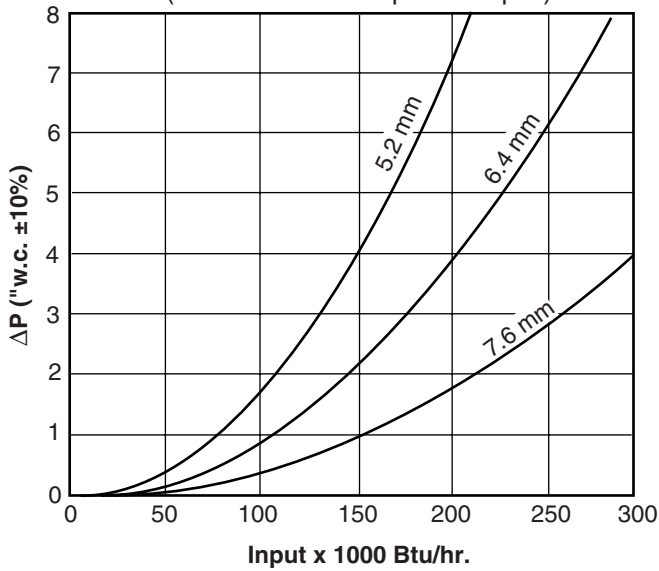

Butane Orifice ΔP vs Input
(Measured from Tap C to Tap D)

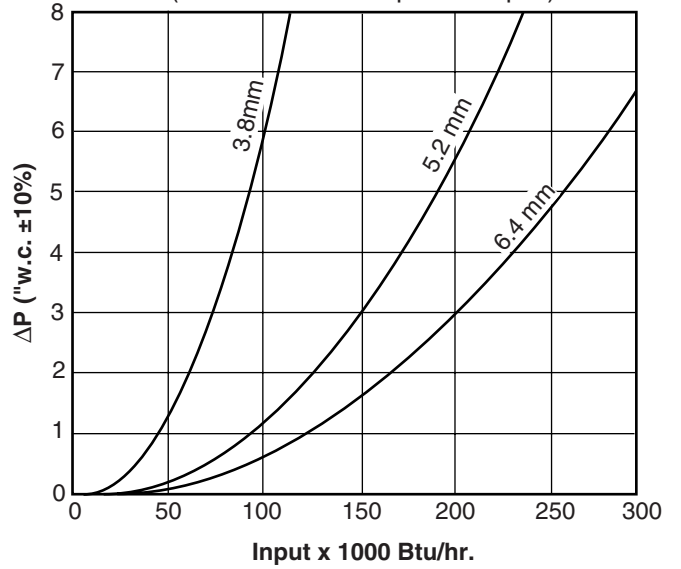

Dimensions & Specifications
Model TFB030
Dimensions in inches (mm)

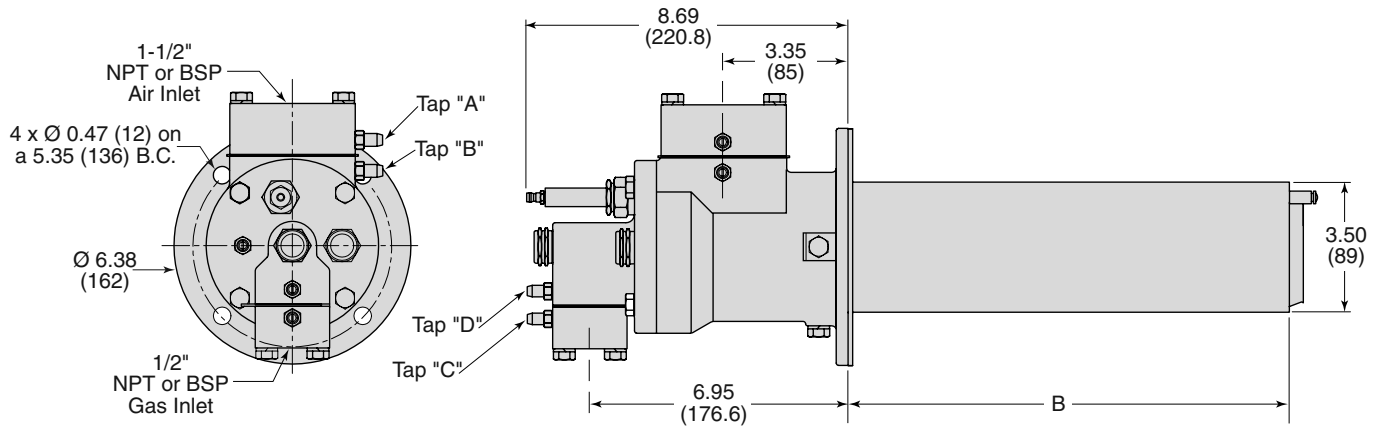

Total Weight 20-25 lb (9-11.3 kg)

Dimension "B"

Each Therm Thief burner is available in a number of variants which have different air tube lengths (dimension "B"). Based on your application, choose the dimension closest to your requirements. Dimension "B" can be from 3" to 24" in one inch increments.



Offered By:

Power Equipment Company
2011 Williamsburg Road
Richmond, Virginia 23231
Phone (804) 236-3800
Fax (804) 236-3882

www.peconet.com